

GPS RTK North Finder

DESCRIPTION

The GPS RTK North Finder is a high-precision navigation system that determines true north using GPS-based real-time kinematic (RTK) technology. Unlike traditional compasses, which are affected by magnetic interference, it calculates heading using satellite signals and advanced positioning methods. This makes the GPS RTK North Finder ideal for environments where magnetic navigation is unreliable, such as areas with strong magnetic interference.

The system operates using two high-precision GPS antennas mounted at a fixed distance from each other. By analyzing the phase difference of the GPS signals received by the antennas, it calculates the exact angle relative to true north and measures the distance between the antennas with accuracy up to 1 cm.

To further improve accuracy, the system uses RTK correction data, reducing positioning error to just a few centimeters—and under optimal conditions, even to the millimeter level. For best performance, a stable data link is required, as RTK technology depends on a base station or a network of reference stations to provide real-time positioning corrections. Initial startup time depends on satellite acquisition and may vary with weather conditions. With its high precision, the GPS RTK North Finder is a valuable tool for applications such as surveying, navigation, and other precision orientation tasks.



FEATURES

- ▶ Support for multiple GNSS constellations, including GPS, GLONASS, Galileo, BeiDou, and QZSS, as well as optimal constellation combinations.
- ▶ Output azimuth accuracy: 0.05 RMS based on a 2 m baseline
- ▶ Higher accuracy can be achieved by increasing the antenna arm length
- ▶ Inclination and position measurement
- ▶ Time to first fix (TTFF): up to 1 minute under open-sky condition
- ▶ IP67 protection
- ▶ Support for RS485, RS232, and CAN communication protocols, depending on the model

Dimension Specifications:

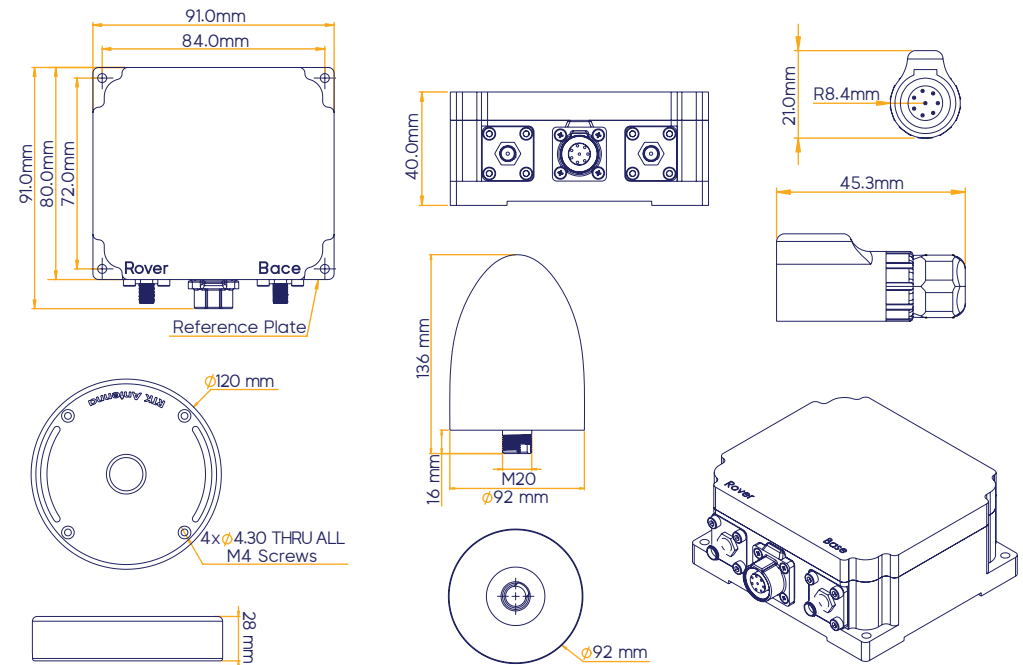

Technical SPEC

Parameter		Value				
Receiver Type		Multi-band GNSS				
Heading Accuracy		0.05°rms (Baseline 2 m)				
Response Time		Environment dependent				
GNSS	GPS+GLO+GAL+BDS	GPS+GLO+GAL	GPS+GAL	GPS+GLO	GPS+BDS	GPS
Acquisition (Cold Start)	25 s	25 s	30 s	25 s	30 s	30 s
Max Navigation Update Rate (RTK)	8 Hz	10 Hz	15 Hz	15 Hz	15 Hz	20 Hz
Convergence Time (RTK)	<10 s	<10 s	<10 s	<10 s	<10 s	<30 s
Horizontal Position Accuracy (CEP) (RTK)	0.01 m +1 ppm	0.01 m +1 ppm	0.01 m +1 ppm	0.01 m +1 ppm	0.01 m +1 ppm	0.01 m +1 ppm
Vertical Position Accuracy (Median) (RTK)	0.01 m +1 ppm	0.01 m +1 ppm	0.01 m +1 ppm	0.01 m +1 ppm	0.01 m +1 ppm	0.01 m +1 ppm
Baseline Accuracy (RTK)	0.01 m	0.01 m	0.01 m	0.01 m	0.01 m	0.01 m
Sensitivity	Tracking And Nav	-167dBm	-			
	Reacquisition	-160dBm				
	Cold Start	-148dBm				
	Hot Star	-157dBm				

GNSS Performance

GPS/QZSS	GLONASS	Galileo	BeiDou	NavIC
L1C/A (1575.420 MHz)	L1OF (1602 MHz+k*562.5 kHz,k = -7,...,6)	E1-B/C (1575.420 MHz)	B1I (1561.098 MHz)	-
L2C (1227.600 MHz)	L2OF(1246 MHz+k*437.5 kHz,k = -7,...,6)	E5b (1207.140 MHz)	B2I (1207.140 MHz)	-

Electronic SPEC

Parameter	Value	Unit
External Power Supply	7~36	V
Current Consumption	80 @ 24 v	mA
Startup Time	Less Than 1 min in Open Sky	
Digital Output	RS485	
Sampling Rate	8 Hz	
Output Data Rate	115200 bit/sec (Default)	
Frame Data Structure	RTU Modbus / ASCII Modbus / String	
Connector	CNLINKO female 8 pin	
Cable Specifications	AWG 1x8x24 (20 cm)	

Mechanical & Environmental SPEC

Parameter		Value	Unit
Main Body	Dimension	91x80x40	mm
	Weight	454	gr
	Material	Hard Anodized Aluminum	-
	Installation Method	Bolt and Nut (M3)	-
Antenna (Selectable)	Dimension	136x92x92	mm
	Weight	326	gr
	Cable Length	1	m
	Connector	UFL (female threaded)	-
	Part Number	AQHA.11	-
Antenna Basis	Installation Method	Nut (M20)	-
	Dimension	120x120x28	mm
	Weight	323	gr
	Material	Hard Anodized Aluminum	-
Installation Method		Bolt and Nut (M3)	-
Operating Temperature		-30 ~ +70	°C
Storage Temperature		-40 ~ +85	°C
Ingress Protection		IP67	-

APPLICATIONS

- ▶ Marine and land applications
- ▶ Precise measurement of position and geographica north direction
- ▶ Accurate navigation in the oil and gas industry