

Horizon Pro Inclinometer

DESCRIPTION

The HORIZON PRO is a high precision, dual axis inclinometer based on advanced MEMS (Micro-Electro-Mechanical Systems) technology.

It measures tilt relative to the local horizon over $\pm 5^\circ$, $\pm 30^\circ$, and $\pm 90^\circ$ ranges with an absolute accuracy better than $\pm 0.015^\circ$.

Equipped with an internal temperature sensor and advanced thermal calibration, the HORIZON PRO offers excellent temperature stability, limiting temperature induced error to within $\pm 0.030^\circ$ across its wide operating temperature range (-30°C to $+70^\circ\text{C}$).

Designed for harsh and demanding environments, it provides robust immunity to electromagnetic interference, shock, and vibration, making it ideal for industrial applications and non-accelerating (static) platforms. The HORIZON PRO integrates easily into monitoring and control systems, providing continuous, real time angle and tilt measurements.

Its three-dimensional acceleration processing ensures consistent accuracy across the entire measurement range. This sensor is widely used in construction, mining, power generation, oil and gas facilities, telecommunications infrastructure, power transmission systems, and geological and structural monitoring where precise inclination and orientation measurements are required.

FEATURES

- ▶ Dual-axis (X, Y) measurement with ranges of $\pm 5^\circ \pm 30^\circ$ and $\pm 90^\circ$ (LS, MS, FS)
- ▶ Absolute accuracy better than $\pm 0.015^\circ$
- ▶ Resolution of 0.001°
- ▶ Maintains accuracy across the full measurement range using 3D acceleration data processing
- ▶ Wide operating temperature range with temperature compensation
- ▶ Maximum temperature induced error within $\pm 0.030^\circ$ over the compensated range
- ▶ IP67 rated environmental protection
- ▶ MEMS based sensor design
- ▶ Supports RS 485, RS 232, and CAN communication interfaces

Dimension Specifications:

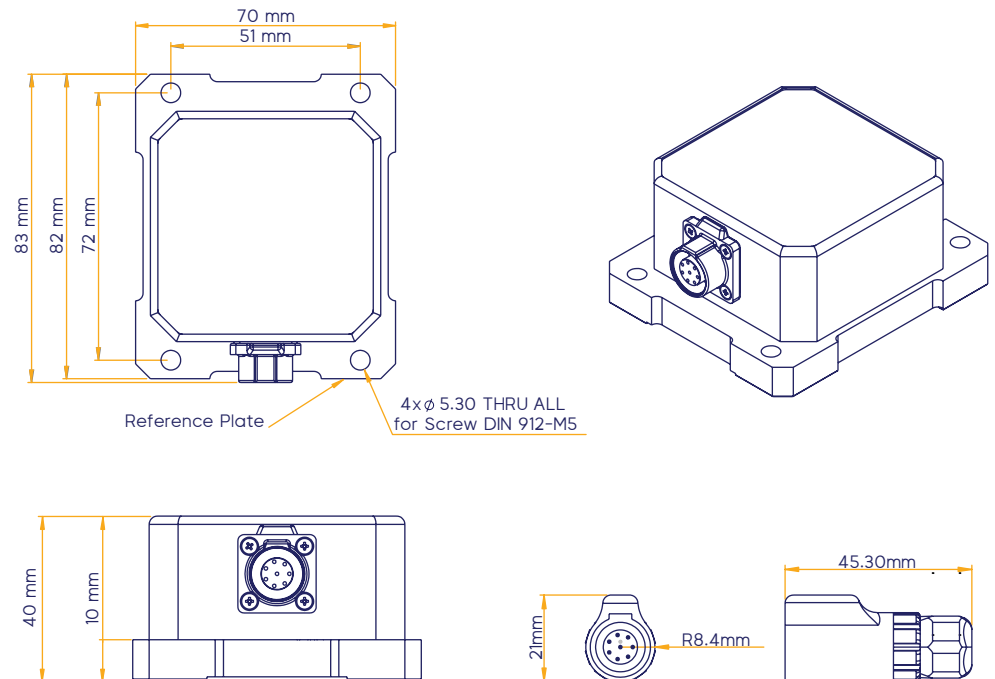

Technical SPEC

| Parameter | Value |
|---|---|
| Axis | Dual-Axis (X,Y) |
| Range | LS : ±5° , MS : ±30° , FS : ±90° |
| Resolution | 0.001° |
| Repeatability | 0.001° |
| Absolute Accuracy @20°C | 0.015° |
| Temperature Drift (Delta From 20°C) *Mv:Measured Value | FS , MS : ±0.0006 °/°C LS : ±(0.01 %Mv +0.0001)°/°C |
| Compensated Temperature | -30°C ~ +70°C |
| Response Time | 0.35 s |
| Long Term Stability (After 1 Year) *Mv:Measured Value | FS : ±(0.037°-0.05% Mv-45°) MS : ±(0.015 °+ 0.03 % Mv) LS : ± 0.015° |

Electronic SPEC

| Parameter | Value | Unit |
|-----------------------|---|------|
| External Power Supply | 7 ~ 36 | V |
| Current Consumption | 15 ~ 25 @24V | mA |
| Startup Time | 1 | s |
| Digital Output | RS485 , RS485- RS232 , RS485 - CAN | |
| Sampling Rate | CAN/RS485/RS485 50Hz (Default) in continuous mode | |
| Output Data Rate | 115200 bit/sec (Default) | |
| Frame Data Structure | Hex / ASCII Modbus / RTU Modbus / String | |
| Connector | CNLINKO female 8 pin | |
| Cable Specifications | Shielded AWG 1x8x24 (17 cm) | |

Mechanical & Environmental SPEC

| Parameter | Value | Unit |
|-----------------------|------------------------|------|
| Dimensions | 82x70x40 | mm |
| Material | Hard Anodized Aluminum | - |
| Weight | 430 | gr |
| Installation Method | Nut and Bolt (M5) | - |
| Operating Temperature | -30 ~ +70 | °C |
| Storage Temperature | -50 ~ +90 | °C |
| Ingress Protection | IP67 | - |

TEMPERATURE SPECIFICATIONS

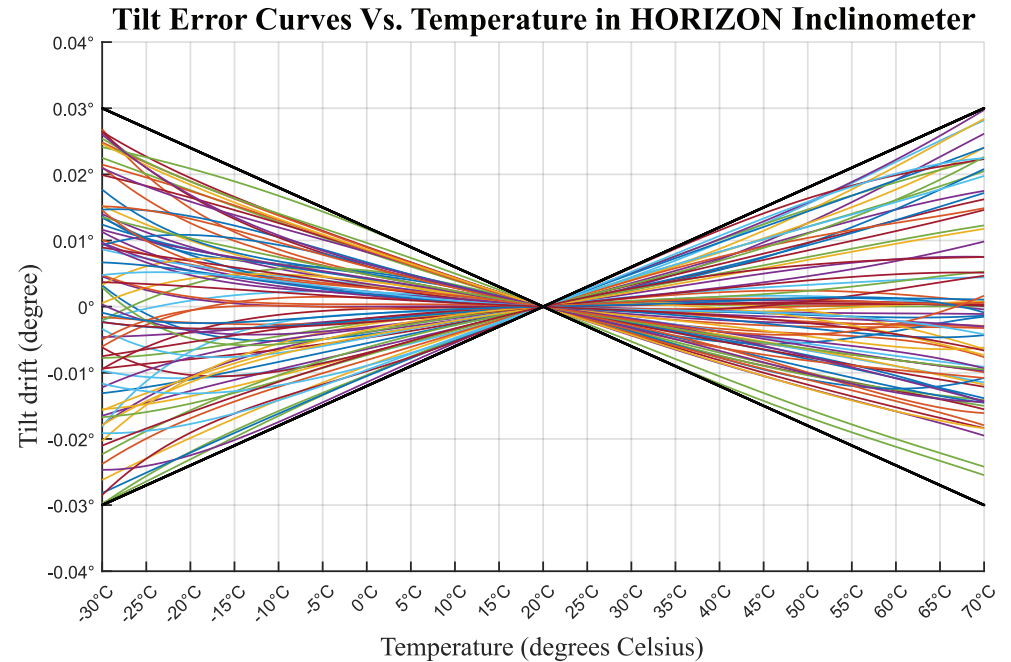

APPLICATIONS

- ▶ Measuring the inclination of surfaces relative to the local horizon or other reference surfaces.
- ▶ Monitoring axes in industrial robots.
- ▶ Adjusting installation angles relative to the local horizon for radio transmitters and receivers.
- ▶ Calibration, monitoring, and leveling of multi-degree-of-freedom tables.
- ▶ Calibration of sensitive medical equipment.
- ▶ Measuring deviation in large pipelines.
- ▶ Installation and monitoring of railway structures.
- ▶ Checking the flatness of machined surfaces using the meshing method.